

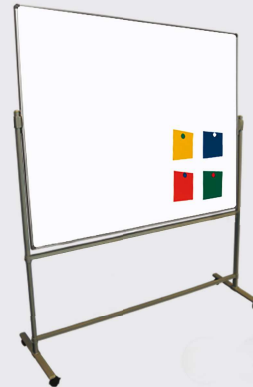





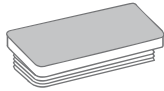

Fixed Mobile Stand Assembly Instructions Sheet

What you will have:

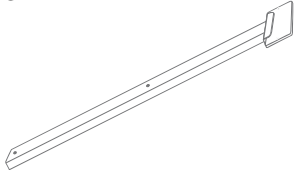
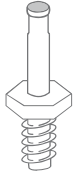
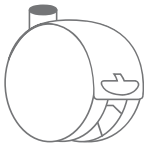
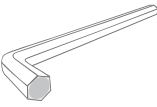
6 x End caps	A
2 x Caster Bar	B
2 x Uprights	C
4 x Caster Shafts	D
4 x Casters	E
1 x 3mm Allen Key	F
4 x M5 16mm Bolts	G
1 x 5mm Allen Key	H
4 x M8 50mm Bolts	I
2 x Cross Members	J + K
4 x M5 30mm Bolts	L
4 x Washer	M

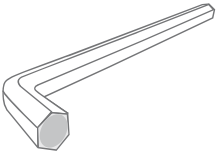
Finished Product:

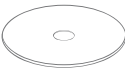

A x 6 	B x 2 	C x 2 	D x 4 
E x 4 	F x 1 	G x 4 	H x 1 
I x 4 	J x 1 	K x 1 	L x 4 
M x 4 			

Before you use your new whiteboard for the first time make sure you clean all the panels thoroughly.
If you have any further enquiries on how to fit your whiteboard please contact our customer service team.

Fixed Mobile Stand Assembly Instructions Sheet

STEP ONE

Fit 4 of the end caps (A) on to both ends of the caster bars (B), fit the last two remaining end caps on to the open ends of the upright members (C). Tap the end caps on with a mallet to ensure they are fully inserted.

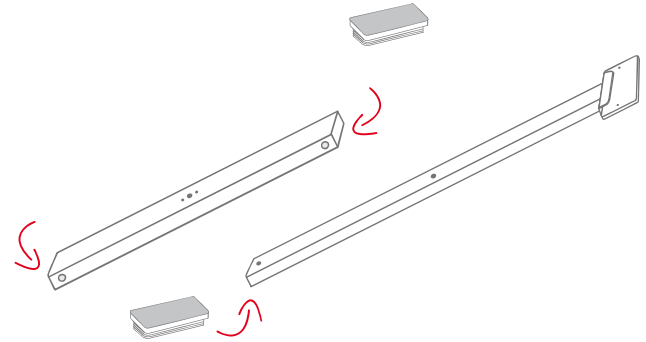

STEP TWO

Screw the caster shafts (D) onto the caster bars (B), using a spanner to make sure that they are fully tightened.

Next attach the casters (E) to the shafts by pushing them on firmly.

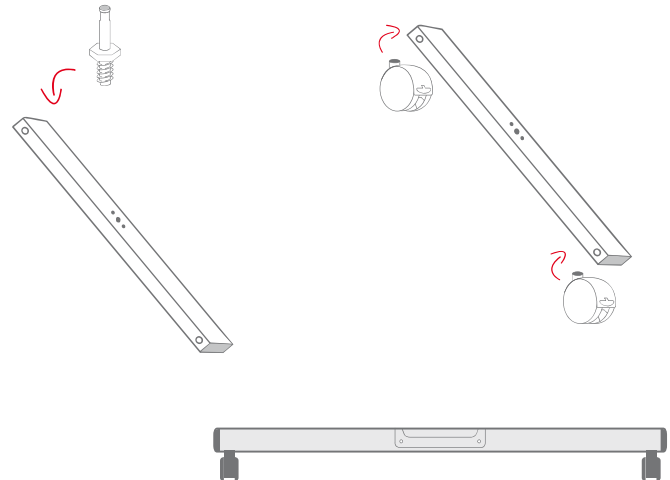

STEP THREE

Align the holes of one of the upright members (C) with the holes of one of the caster bars (B), ensuring that the shorter side of the saddle is facing in towards the whiteboard.

Using the (F) 3mm allen key and the 4 x M5 16mm (G) bolts join uprights to the castor bars.

Repeat this process for the second upright and caster bar.

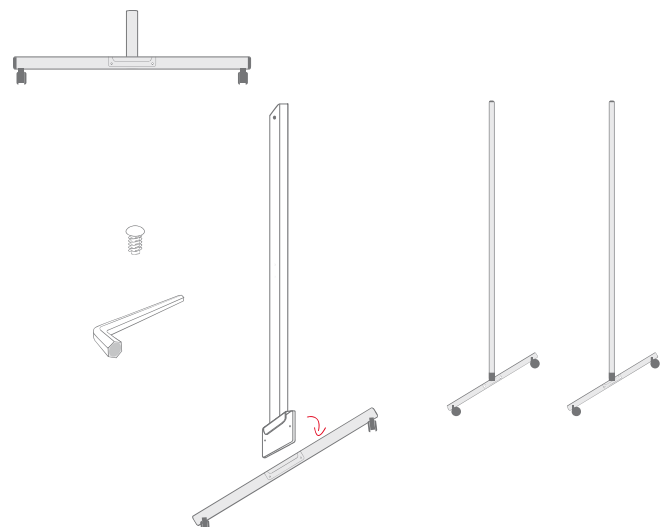

Fixed Mobile Stand Assembly Instructions Sheet

STEP FOUR

Using the (H) 5mm Allen key and the 2 x M8 50mm bolts (I) join the (J) lower cross member to both uprights / castor bars making sure the shorter side of the upright saddle is on the inside.

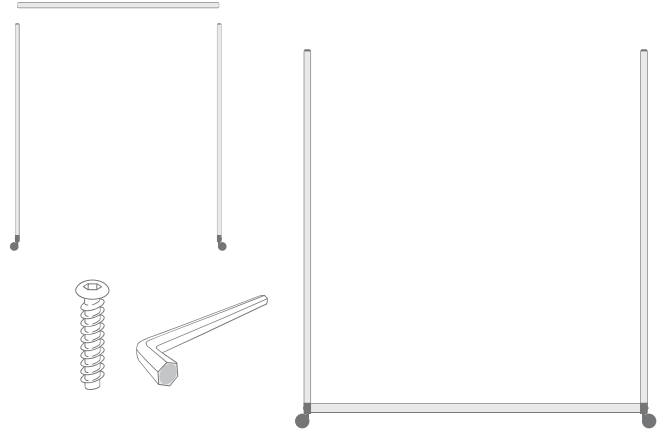

STEP FIVE

Using the remaining 2 x M8 50mm bolts (I) to loosely join upper (K) cross member to stand.

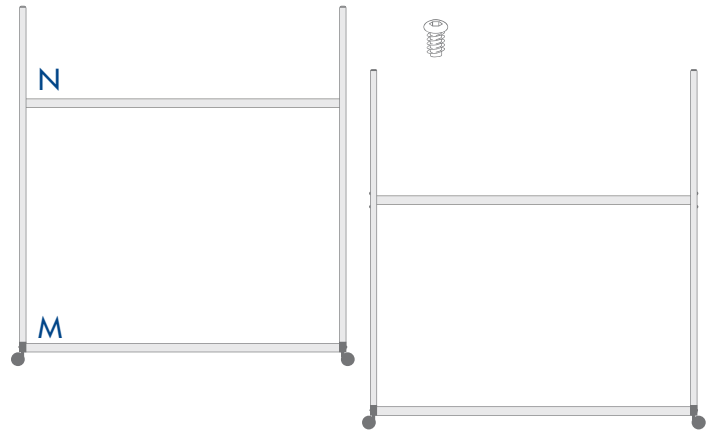

STEP SIX

Align the holes of one side of the board with the holes in the upright (C) and secure together using 2 x M5 30mm bolts (L) and 2 x washers (M). Tighten with the 3mm allen key (F). Repeat this process on the other side of the board.

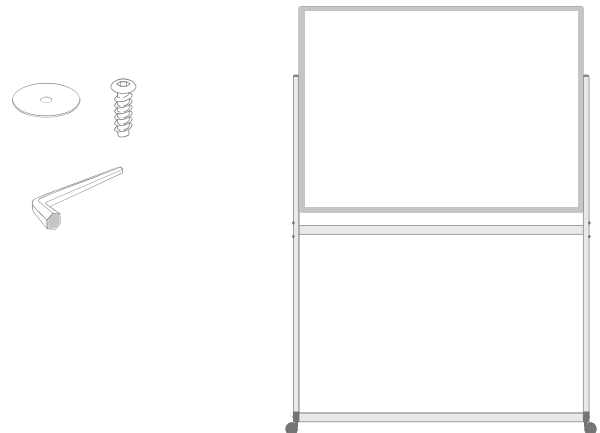



Fixed Mobile Stand Assembly Instructions Sheet

Your Magiboards mobile stand is now ready to use.

Occasionally check bolts and screws for tightness. The mobile stand instructions are available at www.magiboards.com

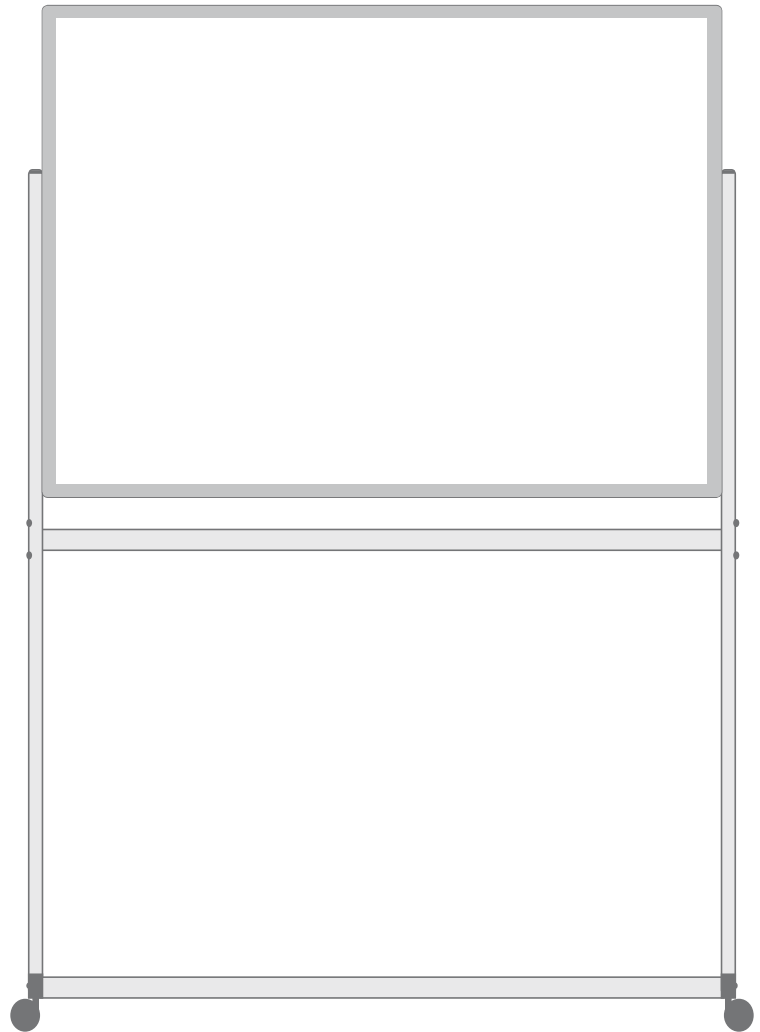
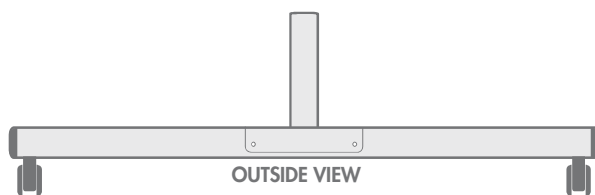

THE FIXED MOBILE STAND RANGE

90 X 120CM MCC205	120 x 120CM MCC208	120 x 120CM MCC210P
<p>W 900mm H 1200mm</p>	<p>W 1200mm H 1200mm</p>	<p>W 1200mm H 1800mm</p>

Create, Shape & Communicate