

Mobile Stand Assembly Instructions Sheet

What you will have:

PACK A:

8 x M6 40mm Bolts	A	2 x Board Brackets	F
4 x Caster Shafts	B	2 x Rubber Circle	G
4 x M6 12mm Bolts	C	6 x End caps	H
1 x Star Washer	D	2 x Locking Handles	I
1 x Allen Key	E	2 x Casters	J

PACK B:

2 x Caster Bar	K
2 x Upright Members	L

PACK B:

1 x Base Cross Member	M
1 x Cross Member with Pen Tray	N

Finished Product:



PACK A A x 8 	PACK A B x 4 	PACK A C x 4 	PACK A D x 4
PACK A E x 1 	PACK A F x 2 	PACK A G x 2 	PACK A H x 6
PACK A I x 2 	PACK A J x 4 	PACK B K x 2 	PACK B L x 2
	PACK C M x 1 	PACK C N x 1 	

Before you use your new whiteboard for the first time make sure you clean all the panels thoroughly. If you have any further enquiries on how to fit your whiteboard please contact our customer service team.

Create, Shape & Communicate

Mobile Stand Assembly Instructions Sheet

STEP ONE

Fit 4 of the end caps (H) on to both ends of the caster bars (K), fit the last two remaining end caps on to the open ends of the upright members (L). Tap the end caps on with a hammer or mallet to ensure they are securely attached.

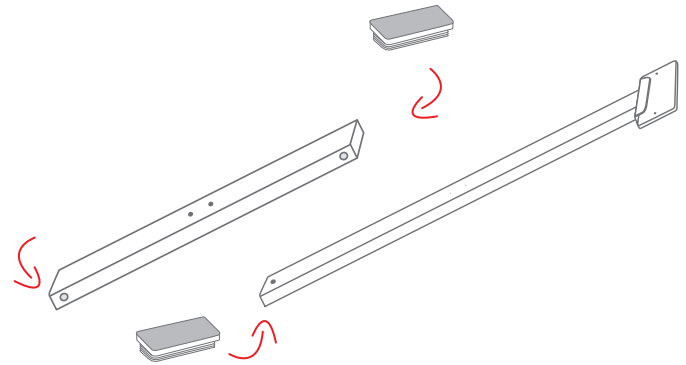

STEP TWO

Screw the caster shafts (B) onto the caster bars (K), using a spanner to make sure that they are suitably tightened. Next attach the castors to their shafts by pushing them on firmly.

Ensure that one locking and one plain castor is fitted to each caster bar, with both locking castors at one end and both plain castors at the other end.

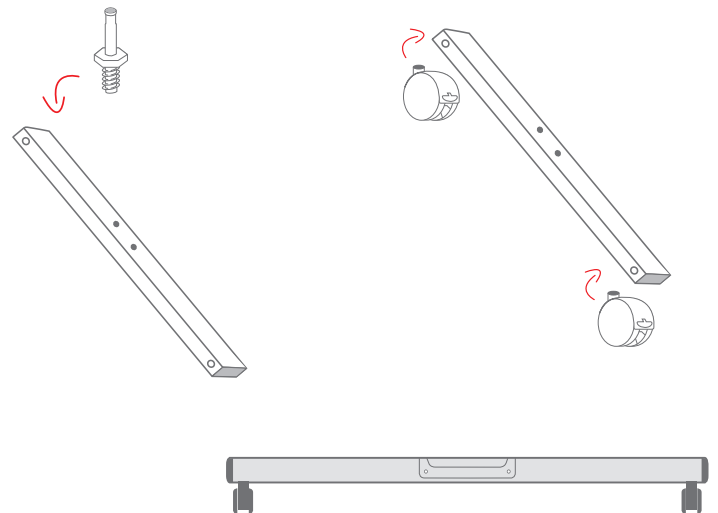

STEP THREE

Next align the holes of one of the upright members (L) with the holes of one of the caster bars (K), ensuring that the longer side of the bracket is facing in towards the future position of the whiteboard.

Repeat this process for the second caster bar.

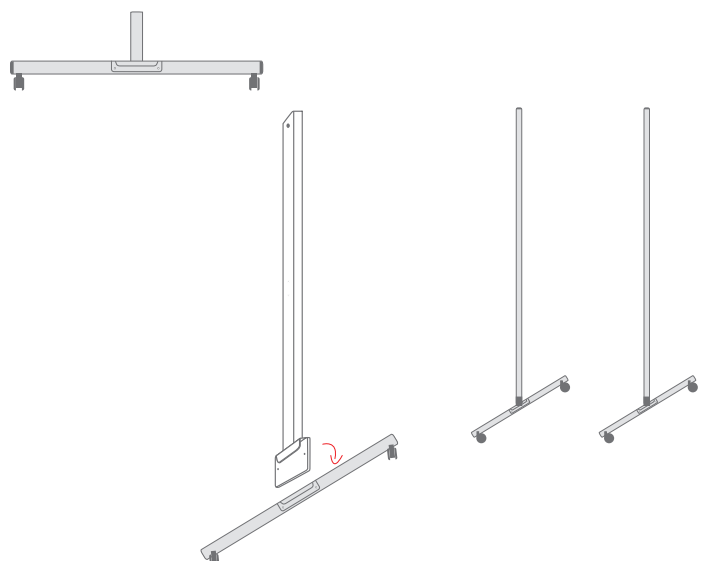

Mobile Stand Assembly Instructions Sheet

STEP THREE

Next align the holes of the base cross member (M) with the holes of the longer side of the bracket of the upright member (L). Place the long domed headed M6 bolt 40mm (A) into the outside of upright members (L) and screw through into the base cross member (M), attaching all three components together.

Tighten with the allen key (E). Repeat this process for the other end of the base cross member (M).

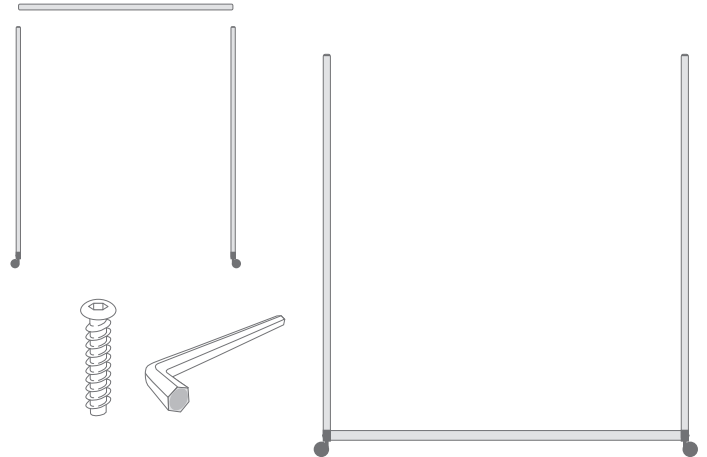

STEP FOUR

The front of the board is the side with the lockable castors. Facing the pen tray on the cross member with pen tray (N) forwards, attach the cross member with pen tray by aligning the holes with those of the upright members (L) and screwing into place using the same long M6 40mm domed headed bolts (A), leave these bolts a little bit loose for now so that the board can be fitted.

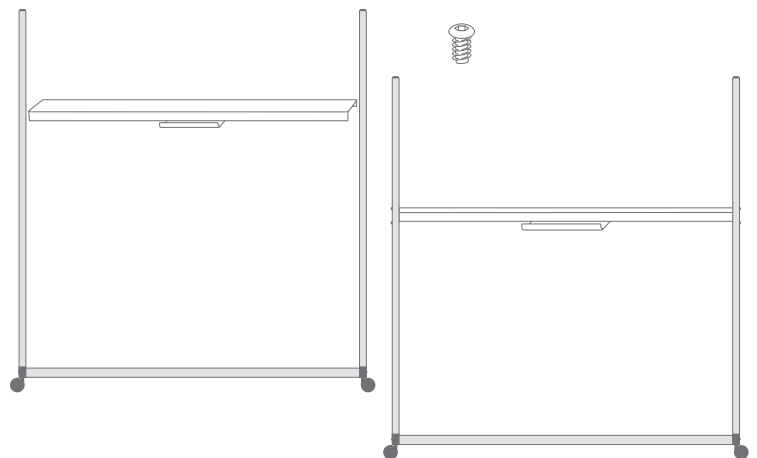

STEP FIVE

Align the holes of one side of the board with the holes of the board end fixing brackets (F) and place two star washers (D) over these holes as well, secure together using the short domed head bolts 12mm (C) and tighten with the allen key (E). Repeat this process at the other end of the board.

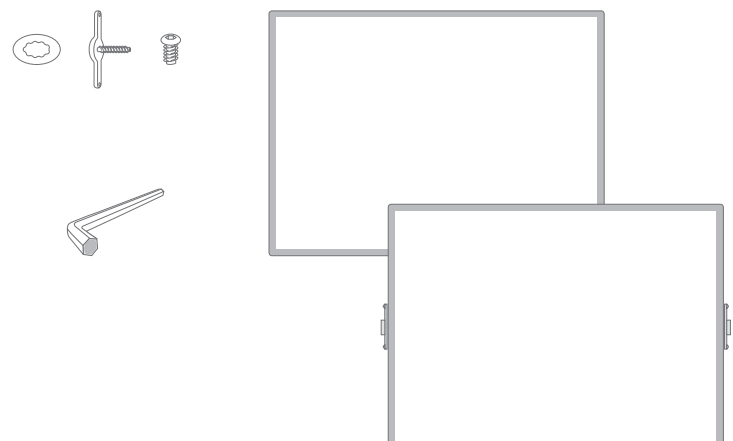

Mobile Stand Assembly Instructions Sheet

STEP SIX

Place the rubber circles (G) over the protruding parts of the side of the board. Next pick up the board and slot it into place at the top of the upright members (L).

Fasten by slotting the locking handle (I) over the ends. Now go back and tighten the bolts in the pen tray cross member with the allen key (E).

Your Magiboards mobile stand is now ready to use. It can be fixed into any position using the locking knobs and locking casters.

Occasionally check bolts and screws for tightness. The mobile stand instructions are available at www.magiboards.com

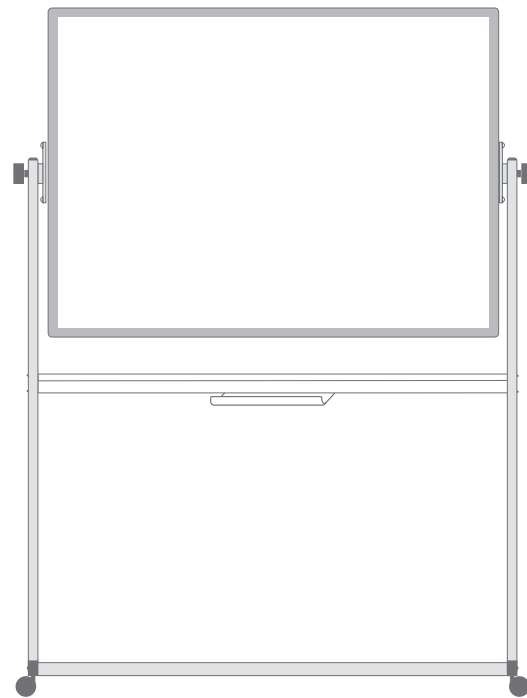
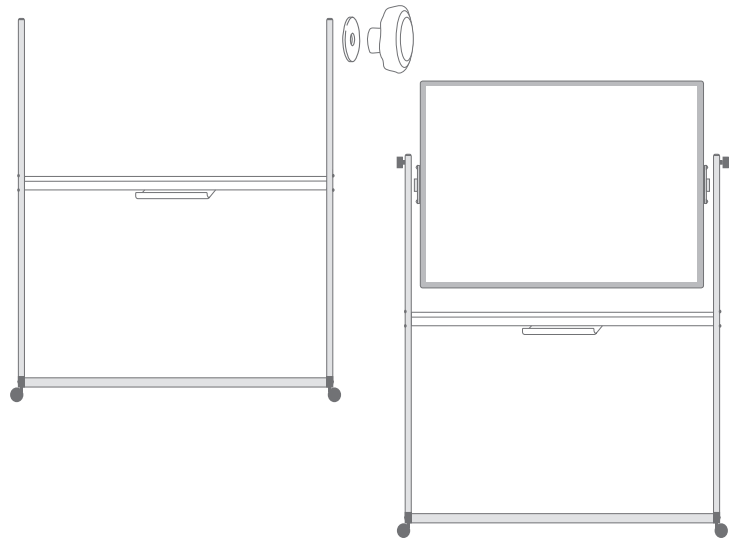

THE MOBILE STAND RANGE

90 X 120CM M?1005	120 x 90CM M?1007	120 x 120CM M?1008	150 x 120CM M?1009	180 x 120CM M?1010	240 x 120CM M?1015

Create, Shape & Communicate

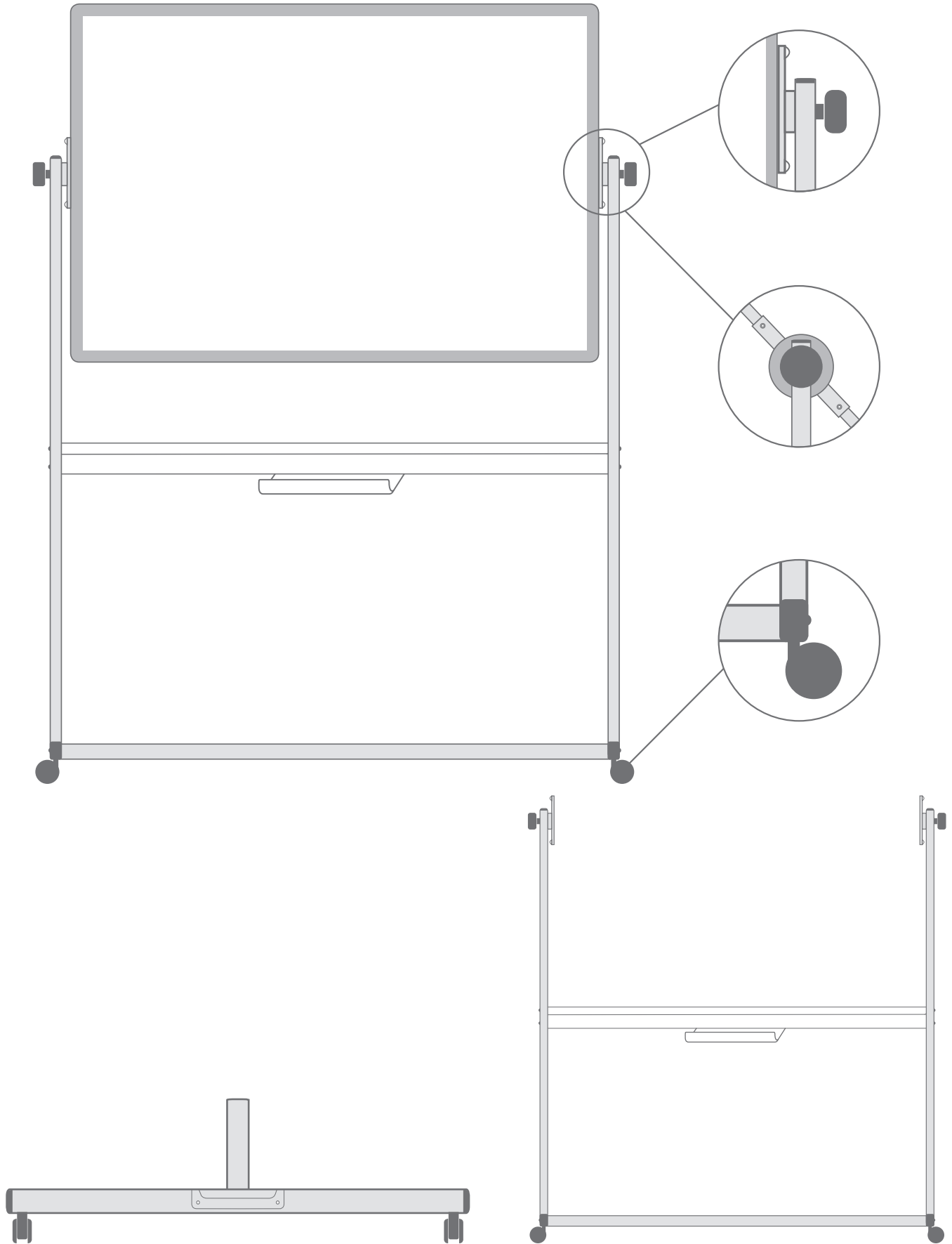

Create, Shape & Communicate